



Vendor Item # YB0565GC (084 09 3479)  
Vase Fountain

Questions, Problems, Missing Parts? Before returning to your retailer,  
**PLEASE CALL CUSTOMER SERVICE at (866) 728-6187**  
9am – 5pm EST, Mon – Fri or e-mail [customerservice@srg-usa.com](mailto:customerservice@srg-usa.com).

### PLEASE READ ALL INSTRUCTIONS BEFORE ASSEMBLY.

Unpack all parts from Styrofoam and bubble wrap inside the carton to ensure there are no missing or damaged parts. If any parts are missing or damaged, do not attempt to assemble or use the product. Please contact customer service for replacement.

#### CARTON CONTENTS:

Part#	Description	Quantity
01.	Top fountain	1
02.	Screw	2
03.	Washer (small)	4
04.	Nut	2
05.	Washer(large)	2
06.	Butterfly nut	2
07.	Basin	1
08.	Pump	1

#### TOOLS REQUIRED FOR ASSEMBLY:

- Wrench (Not Included)

#### ASSEMBLY INSTRUCTIONS:

**Note: This item is fragile. Please be handle gently and with care. It is recommended that two adults assemble the product in order to avoid injury or damaging the item.**

1. Unpack the contents of the box and check to make sure that all items are accounted for and in good condition.
2. Select a flat, level surface for the assembly and final location of your fountain.
3. Place the top fountain on the floor upside down. Lead the bolts with the small washers through the two mounting holes from inside of the top fountain out. Place an additional washer and nut over each bolt and tighten the butts with a wrench. (Fig.1)
4. Place the basin on a flat, level surface. Align the bolts at the bottom of top fountain with the holes on the pedestal in the basin and place the top fountain onto the pedestal. Place the large washers over the bolts and tighten the butterfly nuts to secure the top fountain to the basin pedestal. (Fig.2)
5. Insert the water supply tube from the bottom of top fountain into the pump outlet and then place the pump in the basin upright through the pump gate of the pedestal. (Fig 3)
6. Add clean water into the basin. The water level should be approximately 30mm below the top edge of the basin. (Fig 4)
7. Connect the pump to the proper electrical outlet and the product will begin to function as intended. Gently sweep across the water surface to achieve even water flow across the surface. (Fig 4)
8. After the initial set up, observe the flow of the water over the rim of the water pot. It may be necessary to adjust the level of the basin accordingly to gain an even flow around the rim of the top fountain.
9. To eliminate the possibility of water damage to areas around your fountain, check for leaks and excessive splashing after the initial setup of your fountain. It is highly recommended that this fountain be placed in an area that will not be damaged should the area come in contact with liquid.
10. Do not leave your fountain running for extended periods of time or when no one is present to observe the performance.
11. Check the area around your fountain on a regular basis to ensure that there is no leakage.

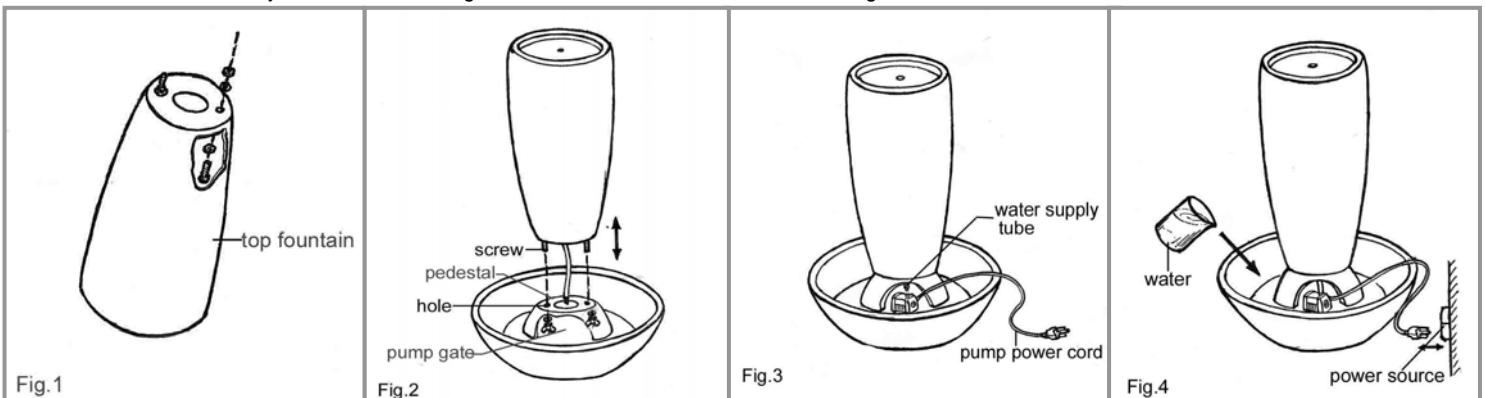
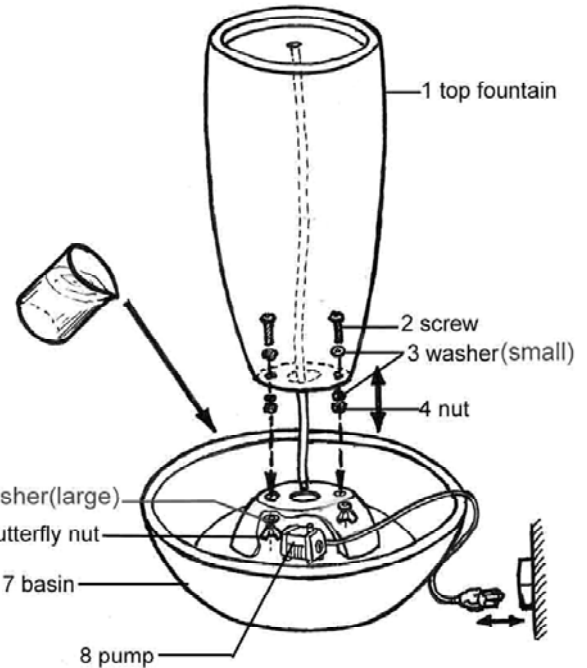

NOTE: The diagrams shown are for illustrative purposes only and are not to scale.

### **MAINTENANCE OF YOUR FOUNTAIN:**

1. Keep water clean - using clean water will reduce mineral deposits and improve water clarity.
2. Clean the fountain periodically to prevent mineral deposits and contamination. Use a wet cloth to gently wipe heavily stained surfaces. **Do not use harsh chemicals or abrasives as this will damage the finished surface and void the warranty.**
3. Add clean water periodically to ensure that the pump is fully submerged in water.
4. Disconnect the power and empty the basin if the fountain will not be used for an extended time.
5. If installed outdoors and in a freeze-area of the country, ensure that all water is removed and the unit is completely dry. **This product is NOT to be operated below 41°F (5°C) or freeze damage may occur.**



### **SPECIAL WARNINGS & CAUTIONS:**

#### **WARNINGS:**

1. To reduce the risk of electric shock, connect only to a properly grounded, grounding type receptacle.
2. Do not exceed the voltage shown on the pump.
3. Always disconnect the pump from the power source prior to beginning any maintenance or work on the pump or fountain.
4. Inspect the power cord for damage before installation and/or maintenance. Replace the entire pump if damage is found.
5. For pumps with a 3-prong, grounded type plug, do not remove the grounding pin from the plug on the power cord.

#### **CAUTIONS:**

1. The fountain shall not be installed within 10 feet (3.05m) of a pool or spa. When the pump is connected to a GFCI protected circuit, the fountain unit has the option of being installed no less than 5 feet (1.52m) from a pool or spa.
2. Use only with portable, self contained fountains no larger than 5' in any direction.
3. Use a proper power source as indicated on the pump label. Keep the cord away from high temperature and/or heat sources.
4. Do not lift the pump by its power cord.
5. Keep the fountain out of reach of children.
6. Do not let the pump run dry. Pump must be completely submerged for proper operation and cooling.
7. Do not pump heated liquids.
8. Operate in freshwater only. Avoid heavily chlorinated water and water with high PH levels.

#### **PUMP ASSEMBLY INSTRUCTIONS:**

1. Remove the pump from the package and untie the power cord.
2. Place the pump in the desired location in your pond or fountain ensuring that it is completely submerged in the water. If the pump is to be used in a pond, raise the pump off of the pond floor to ensure that it is above any dirt that will collect, as this will adversely affect the performance of the pump.
3. Adjust the flow rate (if applicable) to the maximum (+) position.
4. Connect the power cord from the pump to a properly grounded, grounding type receptacle (GFCI).
5. If necessary, readjust the flow rate to the desired level (remember to always disconnect from the power source before handling the pump).

#### **CARE & MAINTENANCE:**

1. Keep the water clean – clean water will prolong the useful life of your pump.
2. Use a pre-filter on your pump if available.
3. Regular cleaning of the pump will be necessary depending upon the environment in which it is operated. Clean the pump when it is visibly soiled or when a noticeable drop in performance is detected. **Failure to clean the pump will result in overheating of the pump and the voiding of the warranty!**
4. Before cleaning, always disconnect the pump from the power source.
5. Disassemble the pump by removing the inlet screen & the impeller housing. Remove the impeller/rotor assembly by gently pulling on the impeller blades. Use a soft cloth or brush to clean the area inside of the pump where the impeller/rotor assembly was. Clean the inlet screen, impeller housing & impeller in warm soapy water. Reassemble the pump and inspect for proper operation.

#### **HINTS & TROUBLESHOOTING:**

1. Ensure that the pump's flow control switch is set to maximum (+) before operating. Once the flow is established, the pump can be adjusted downward to the desired level.
2. If the pump operates, but there is no flow, check to ensure the pump is fully submerged.
3. If the pump operates, but there is no flow, check the supply tubing for kinks and correct.
4. If the pump operates, but there is no flow, and if the pump is submerged and there are no kinks in the supply tubing, lift the pump from the water. Remove supply tubing at pump outlet and clean tubing inside and out if necessary. Reset pump in water (outlet side up) and once water begins to flow, re-attach the supply tubing.

***Pump is replaceable with model # PT-505***

#### **SAVE THESE INSTRUCTIONS!**

Each Peaktop product may have variations in texture, finish and appearance from one unit to the next. This enhances the beauty of the product and makes your Peaktop product uniquely individual. Some products and finishes are intentionally weathered or worn in appearance for aesthetic design.

**Ref. #XXXXXX**  
**Printed in China**