



Item # 247687

LION HEAD FOUNTAIN

Model # F30275AB



Questions, Problems, Missing Parts? Before returning to retailer, call our customer service department at 866-728-6187 from 9 a.m. – 5 p.m. EST, Monday – Friday, or e-mail customerservice@srg-usa.com.

PLEASE READ ALL INSTRUCTIONS BEFORE ASSEMBLY.

Unpack all parts from Styrofoam and bubble wrap inside the carton to ensure there are no missing or damaged parts. If any parts are missing or damaged, do not attempt to assemble or use the product. Please contact customer service for replacement.

Part	Quantity
Top Fountain	1 pc
Screw	2 pc
Washer	2 pc
Pump	1 pc
Basin	1 pc
Trap Door	1 pc

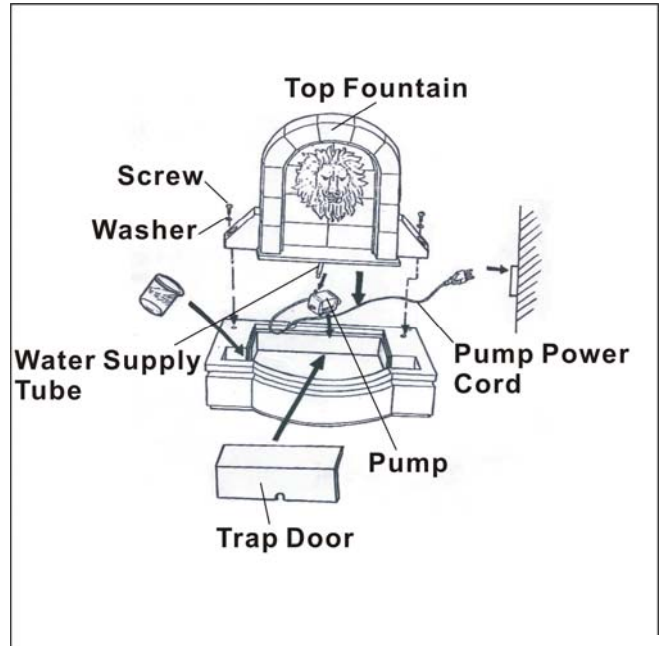

NOTE: Diagram shown is for illustrative purposes only.

⚠ Warnings and Cautions

Warnings:

- To reduce the risk of electric shock, connect pump only to a Ground Fault Circuit Interrupter (GFCI) outlet.
- Do not exceed the voltage shown on the pump.
- Always disconnect the pump from the power source before performing any maintenance or work on the pump or fountain.
- Inspect the power cord for damage before installation and/or maintenance. Replace the entire pump if damage is found.
- Do not remove the grounding pin from the power cord on pumps with a three-prong, grounded-type plug.

Cautions:

- Do not install the fountain within 10 ft. (3.05 m) of a pool or spa. If the pump is connected to a Ground Fault Circuit Interrupter (GFCI) protected circuit, the fountain can be installed no less than 5 ft. (1.52 m) from a pool or spa.
- Use the pump only with portable, self-contained fountains no larger than 5 ft. in any dimension.
- Use a proper power source as indicated on the pump label. Keep the cord away from high temperatures and/or heat sources.
- Do not lift the pump by its power cord.
- Keep the fountain out of reach of children.
- Do not let the pump run dry. Pump should be completely submerged for proper operation and cooling. This pump (120Vac, 60Hz) is installed with Thermal cutoff device. Thermal cutoffs are non-resetting type, thermally-sensitive devices that are designed to protect electrical appliances and industrial equipment from fire. When this pump does run in abnormal conditions or dry conditions without water, the temperature of pump body raises over safety point in which the thermal protector's cut off point is triggered. The thermal protector will break the electrical circuit and prevent pump body overheat damage. When the temperature of pump body is cool to certain value of reset of thermal protector, the thermal protector will restore and the circuit will be closed again, so this pump will restart to operate. This protection function of pump can cut off and restart this pump in periodical cycle.
- Do not pump heated liquids.
- Operate with freshwater only. Avoid heavily chlorinated water and water with high pH levels.

Preparation

Before beginning assembly, read all warnings and safety precautions. Remove parts from carton. Compare parts with parts list. If any part is missing or damaged, do not attempt to assemble or use the product. Contact customer service for replacement.

Estimated time for assembly is 15 minutes.

Tools required for assembly:

- Screwdriver (not included)

Assembly Instructions

1. Unpack the contents of the box and check to make sure that all items are accounted for and in good condition.
2. Select a flat, level surface for the assembly and final location of your fountain.
3. Place the basin flat on a horizontal ground. Fill the basin with clean water. The water level should be approximately 30 mm below the top edge of the basin. (Fig.1)
4. Insert the water supply tube extending from the underside of the top fountain into the outlet on the pump. Then place the top fountain onto the basin securely and levelly. And place the pump to the pump chamber (NOTE: Route the pump power cord from the cord slot on the bottom of Top fountain). Align the holes on the top fountain with the holes on the basin and secure using screws and washers. Insert the tongue upwards and Attach the trap door over front of the pump chamber. (Fig.2)
5. Plug the power cord from the pump into the Ground Fault Circuit Interrupter (GFCI) outlet. Turn the power source on. The product will start to function as intended. (Fig.3)
6. To eliminate the possibility of water damage to areas around your fountain, check for leaks and excessive splashing after the initial setup of your fountain. It is highly recommended that this fountain be placed in an area that will not be damaged should the area come in contact with liquid.
7. Do not leave your fountain running for extended periods of time when no one is present to observe the performance.
8. Check the area around your fountain on a regular basis to ensure that there is no leakage.

Pump Maintenance Instructions

- Regular cleaning of the pump is necessary.
- Keep water clean to prolong the life of pump.
- Clean pump when it is dirty or when a drop in performance is detected. Use warm, soapy water and a stiff brush for heavily stained surfaces. Do NOT use harsh chemicals, as this will damage the surface finish.
- Failure to clean the pump will result in overheating and voiding of the warranty.
- Use a filter on pump if available.
- Disconnect the power and empty the reservoir if the fountain will not be used for an extended time.
- Do NOT operate fountain in temperatures below 41°F (5°C). Freeze damage may occur. If the fountain is kept outdoors in freezing temperatures, make sure all water is removed and the unit is completely dry.

To disassemble pump for cleaning:

1. Always disconnect pump from the power source before cleaning.
2. Remove the inlet screen and impeller housing.
3. Remove the impeller/rotor assembly by gently pulling on the impeller blades.
4. Use a soft cloth or brush to clean the impeller/rotor assembly area inside the pump.
5. Clean the inlet screen, impeller housing and impeller with warm, soapy water.
6. Reassemble the pump and check for proper operation.

Hints and Troubleshooting

- If the pump operates but there is no flow, check to make sure that the pump is fully submerged.
- If the pump operates but there is no flow, check the supply tubing for kinks and correct.
- If the pump operates but there is no flow, and if the pump is submerged and there are no kinks in the supply tubing, lift the pump out of the water. Remove supply tubing at pump outlet and clean tubing inside and out if necessary. Put pump back into water (outlet side up). Once water begins to flow, reattach the supply tubing.

Pump is replaceable with model # PT-505 UL. Call Customer Service at 866-728-6187 for replacement parts.

SAVE THESE INSTRUCTIONS!

Note: Each Garden Treasures fountain product may have variations in texture, finish and appearance from unit to unit. This enhances the beauty of the product and makes each Garden Treasures fountain product unique. Some products and finishes are intentionally weathered or worn in appearance for aesthetic design.

1- Year Limited Warranty

(Valid in USA and Canada only)

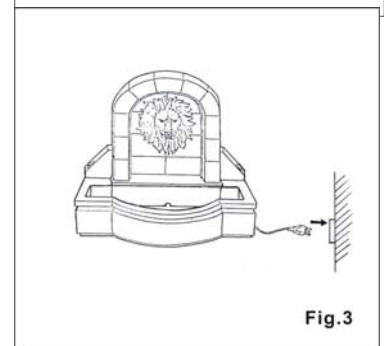
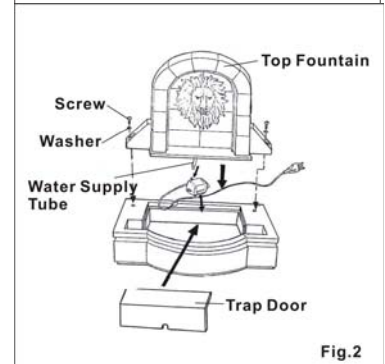
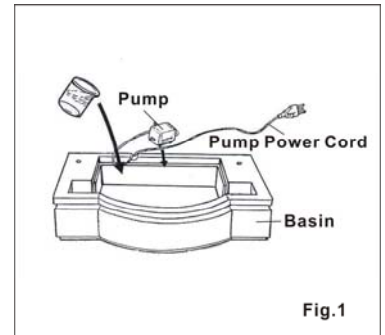

Peaktop warrants this product to be free from defect in material and workmanship for a period of one year from the date of original retail purchase and as set forth below.

Repair/ Replacement Warranty: Pursuant to this Limited Warranty, Peaktop will, at its option,(i) repair the product using new or refurbished parts or (ii) replace the product with a new or refurbished product. In the event of a defect, these are your exclusive remedies. For purposes of this Limited Warranty, "refurbished" means a product or part that has been returned to original specifications.

This Peaktop product warranty does not cover damage caused by misuse or abuse; accident; the attachment of any unauthorized accessory; alteration to the product; or any other conditions whatever that are beyond the control of Peaktop. This warranty is effective only if the product is purchased and operated in the USA and Canada. A product that requires modification or adaptation to enable it to operate in any country other than the country for which it was designed, manufactured, approved, and/or authorized or repair of products damaged by these modifications is not covered under warranty. Peaktop shall not be responsible for any type of incidental, consequential or special damages. All implied warranties, including but not limited to those implied warranties of fitness and merchantability, are limited in the total duration of one year from the original purchase date.

To obtain warranty service on your Peaktop product, either hand deliver or mail the unit and your dated sales receipt (as proof of purchase), freight prepaid, in either its original packaging or packaging affording an equal degree of protection to the Peaktop authorized service facility specified. For specific instructions on how to obtain warranty service for your product,

Email Peaktop : customerservice@srg-usa.com.

Or call the Peaktop Customer Information Service Center
866-728-6187

For an accessory or part not available from your authorized dealer, call:
866-728-6187

Upon receipt, Peaktop will repair or replace, as appropriate, your product and return it to you, postpaid.

If it is appropriate to replace your product. Peaktop will replace the product with the same product or a comparable product at Peaktop's option. Warranty is solely through Peaktop Customer Service Center. Service of this product by anyone other than Peaktop Center voids warranty.

This warranty provides you with specific legal rights. You may have additional rights, which may vary from state to state. Because of individual state regulations, some of the above limitations and exclusions may not apply to you.

Printed in China