



Item # 243798

2 TIER FOUNTAIN WITH TORCH

Model # 24-28



Questions, Problems, Missing Parts? Before returning to retailer, call our customer service department at 1-866-432-5867 from 8 a.m. – 6 p.m. EST, Monday – Friday, or e-mail customerservice@pttechnologies.com.

Part	Quantity
Top Fountain	1 pc
Basin	1 pc
Pedestal	1 pc
Oil Lamp	1 pc
Pump	1 pc

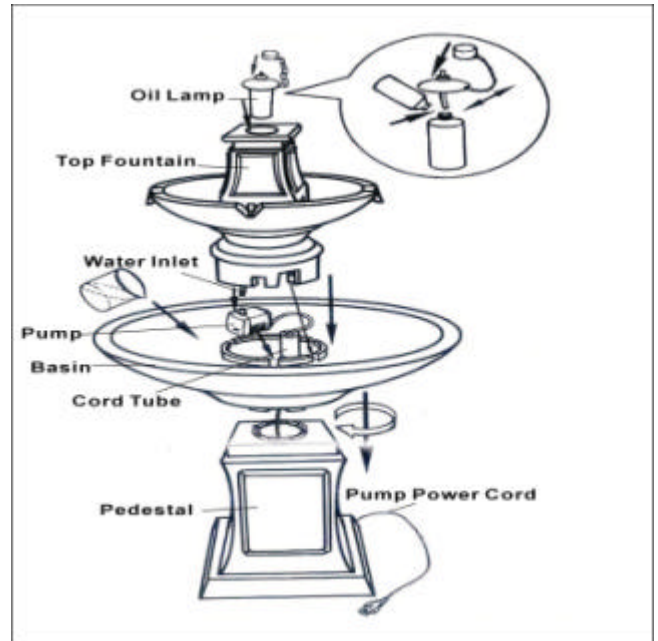

Warnings and Cautions

Warnings:

- To reduce the risk of electric shock, connect pump only to a Ground Fault Circuit Interrupter (GFCI) outlet.
- Do not exceed the voltage shown on the pump.
- Always disconnect the pump from the power source before performing any maintenance or work on the pump or fountain.
- Inspect the power cord for damage before installation and/or maintenance. Replace the entire pump if damage is found.
- Do not remove the grounding pin from the power cord on pumps with a three-prong, grounded-type plug.

NOTE: Diagram shown is for illustrative purposes only.

Cautions:

- Do not install the fountain within 10 ft. (3.05 m) of a pool or spa. If the pump is connected to a Ground Fault Circuit Interrupter (GFCI) protected circuit, the fountain can be installed no less than 5 ft. (1.52 m) from a pool or spa.
- Use the pump only with portable, self-contained fountains no larger than 5 ft. in any dimension.
- Use a proper power source as indicated on the pump label. Keep the cord away from high temperatures and/or heat sources.
- Do not lift the pump by its power cord.
- Keep the fountain out of reach of children.
- Do not let the pump run dry. Pump must be completely submerged for proper operation and cooling.
- Do not pump heated liquids.
- Operate with freshwater only. Avoid heavily chlorinated water and water with high pH levels.

Preparation

Before beginning assembly, read all warnings and safety precautions. Remove parts from carton. Compare parts with parts list. If any part is missing or damaged, do not attempt to assemble or use the product. Contact customer service for replacement.

Assembly Time: Approx. 15 minutes

No Tools Required for Assembly.

Assembly Instructions

1. Unpack the contents of the box and check to make sure that all items are accounted for and in good condition.
2. Select a flat, level surface for the assembly and final location of your fountain.
3. Place the reverse side of the basin on the flat surface. Attach the basin to the pedestal by lining up the corresponding fittings and turn until basin is locked onto pedestal. Then turnover the pedestal and locate it on a flat, level surface. (Fig.1)
4. Lead the pump power cord from the cord slot on the bottom of the pedestal via cord tube

attached at the basin. Insert the water inlet into the outlet on the pump and position top fountain to the central part of the basin. (Note: When placing the top fountain onto the basin be sure to line up the corresponding fittings and place the pump to the basin). (Fig.2)

5. Fill the basin with clean water. The water level should be below the edge of the basin. (Fig.3)
6. Plug the power cord from pump into the electrical outlet. Turn the power source on. The pump will begin to operate.
7. Place the oil lamp on the head of the top fountain and ignite using a match if needed. (Fig.3)
8. To ensure proper water flow make sure locations marked "A-A", "B-B" are wedged together before the connection of each pillar and basin.

INSTRUCTIONS FOR OIL LAMP (Fig.4)

1. Filling: Unscrew flame guard and wick assembly from the fuel canister by turning in a counter-clockwise direction. Fill fuel container with citronella torch fuel. Screw flame guard and wick assembly back onto fuel canister. Do not over tighten. Do not fill past line marked on canister.
2. Lighting: Allow the wick to become completely saturated with oil before lighting. Do not set wick higher than 1/2 inch above top of flame guard. Keep loose clothing, hair and face from coming in contact with flame when lighting.
3. Extinguishing: A snuffer cap has been provided for this purpose. Carefully place snuffer cap completely over wick and leave in place until the flame has completely gone out.

MAINTENANCE:

1. Do not ignite the wick when it's raining. Keep the snuffer cap over the wick to prevent rain from entering the fuel canister.
2. Use only citronella oil. Never use gasoline or other flammable fuel in this torch.

WARNINGS:

1. **DANGER: TORCH FUEL IS HARMFUL OR FATAL IF SWALLOWED.**
2. Read warning on torch fuel packaging carefully.
3. Place torch away from other combustibles such as wooden structures, fuels, clothing and fabrics or dry vegetation.
4. Never leave a burning torch unattended.
5. Keep out of reach of children.

Pump Maintenance Instructions

- Regular cleaning of the pump is necessary.
- Keep water clean to prolong the life of pump.
- Clean pump when it is dirty or when a drop in performance is detected. Use warm, soapy water and a stiff brush for heavily stained surfaces. Do NOT use harsh chemicals, as this will damage the surface finish.
- Failure to clean the pump will result in overheating and voiding of the warranty.
- Disconnect the power and empty the reservoir if the fountain will not be used for an extended time.
- Do NOT operate fountain in temperatures below 41°F (5°C). Freeze damage may occur. If the fountain is kept outdoors in freezing temperatures, make

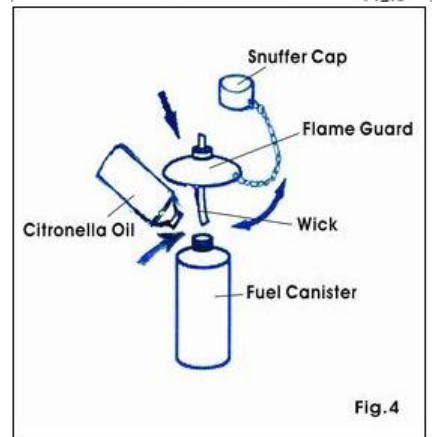
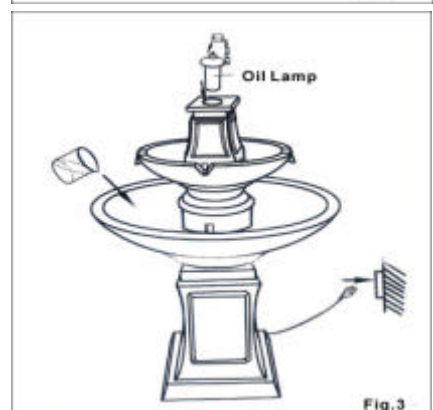
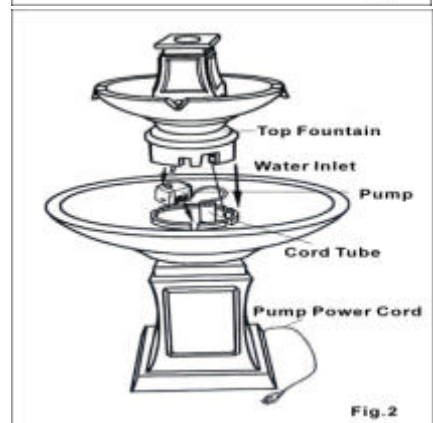
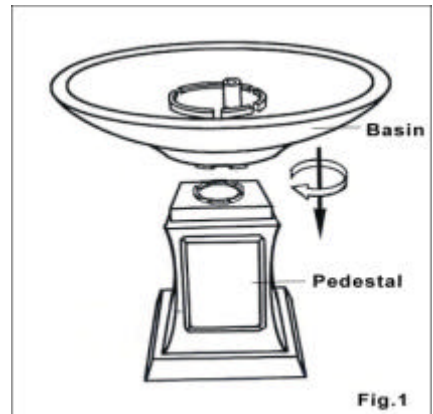

sure all water is removed and the unit is completely dry.

- To eliminate the possibility of water damage to areas around your fountain, check for leaks and excessive splashing after the initial setup of your fountain. It is highly recommended that this fountain be placed in an area that will not be damaged should the area come in contact with liquid.
- Do not leave your fountain running for extended periods of time when no one is present to observe the performance.
- Check the area around your fountain on a regular basis to ensure that there is no leakage.

To disassemble pump for cleaning:

1. Always disconnect pump from the power source before cleaning.
2. Remove the inlet screen and impeller housing.
3. Remove the impeller/rotor assembly by gently pulling on the impeller blades.
4. Use a soft cloth or brush to clean the impeller/rotor assembly area inside the pump.
5. Clean the inlet screen, impeller housing and impeller with warm, soapy water.
6. Reassemble the pump and check for proper operation.

Hints and Troubleshooting

- If the pump operates but there is no flow, check to make sure that the pump is fully submerged.
- If the pump operates but there is no flow, check the supply tubing for kinks and correct.
- If the pump operates but there is no flow, and if the pump is submerged and there are no kinks in the supply tubing, lift the pump out of the water. Remove supply tubing at pump outlet and clean tubing inside and out if necessary. Put pump back into water (outlet side up). Once water begins to flow, reattach the supply tubing.

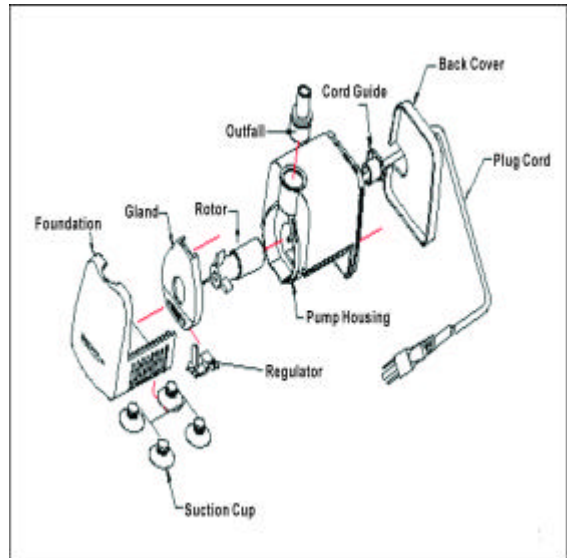

Pump is replaceable with model # PT-707MIX. Call Customer Service at 1-866-432-5867 for replacement parts.

SAVE THESE INSTRUCTIONS!

Note: Each Garden Treasures fountain product may have variations in texture, finish and appearance from unit to unit. This enhances the beauty of the product and makes each Garden Treasures fountain product unique. Some products and finishes are intentionally weathered or worn in appearance for aesthetic design.

Printed in China