



Item #105852 Bretagne Fountain

Questions, Problems, Missing Parts?

Before returning to retailer, please call customer service at (866) 728-6187 from 9am – 4pm (EST), Mon – Fri or e-mail customerservice@silkroadgifts.com.

PLEASE READ ALL INSTRUCTIONS BEFORE ASSEMBLY.

Unpack all parts from the carton to ensure there are no missing or damaged parts. If any parts are missing or damaged, do not attempt to assemble or use the product. Please contact customer service for replacement.

Carton Contents

Fountain Top	1 pc.
Pedestal	1 pc.
Basin	1 pc.
Pump w/Lamp Chain	1 pc.
Transformer	1 pc.

Replacement Parts (Not included)

Bulb: MR-11 type halogen bulb,
12 volts, 10 watts maximum
Pump: #PT-505(O)3LT10
Transformer: #66C.YL-55-12V

Contact Customer Service for
missing parts.

If the fountain top, pedestal or basin
are missing or damaged, the unit
must be returned to or exchanged at
the retailer.

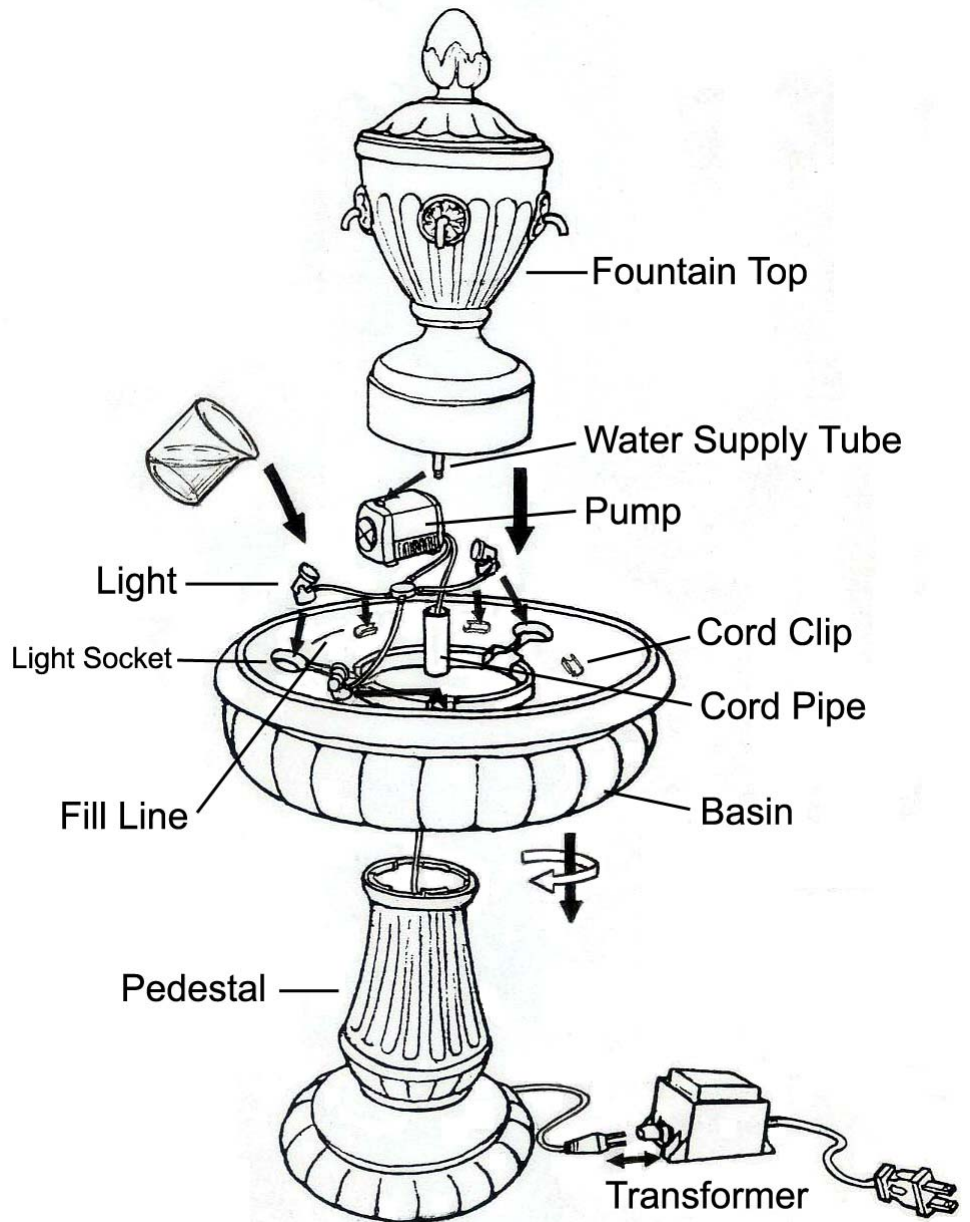

NOTE: Diagram for illustrative purposes only and not to scale. There may be technical and design modifications to constantly improve this product.

IMPORTANT SAFETY INSTRUCTIONS

When using electrical products, basic precautions should always be practiced including the following:

1. READ AND FOLLOW ALL SAFETY INSTRUCTIONS.

2. Read and follow all instructions that are on the product or provided with the product.
3. For a cord-connected or direct plug-in power unit, do not use an extension cord.
4. Reference the National Electrical Code, ANSI/NFPA 70, specifically for the installation of wiring and clearances from power and lighting conductors.
5. Installation work and electrical wiring must be done by qualified person(s) in accordance with all applicable codes and standards, including fire-rated construction.
6. Do not install the fountain within 3.05 m / 10 ft of a pool or spa. When the pump is connected to a GFCI-protected circuit, the fountain unit has the option of being installed no less than 1.52 m / 5 ft from a pool or spa.
7. For a cord-connected or direct plug-in unit, do not use in a bathroom.
8. For a direct plug-in or cord-connected power unit:

WARNING: Risk of Electric Shock. When used outdoors, install only to a covered Class A GFCI protected receptacle that is weatherproof with the power unit connected to the receptacle. If one is not provided, contact a qualified electrician for proper installation. Ensure that the power unit and cord do not interfere with completely closing the receptacle cover.

9. For a permanently connected power unit:

WARNING: Risk of Electric Shock. When used outdoors, install only on a circuit protected by a Class A GFCI.

10. **WARNING:** Risk of Fire. Installation involves special wiring methods to run wiring through a building structure. Consult a qualified electrician.

11. For a unit intended to be mounted at a height greater than 0.3 m / 1 ft from the ground surface.

WARNING: Risk of Electric Shock. Mount the unit at a height greater than 1 foot from the ground surface.

SAVE THESE INSTRUCTIONS – This manual contains important safety and operating instructions for power units.

ADDITIONAL WARNINGS AND CAUTIONS

- This fountain was designed and intended for outdoor use only.
- Please make sure you are using the proper power source as indicated.
- Do not exceed the voltage shown on the pump and/or transformer.
- Keep the power cord away from high temperatures, heat sources and sharp points or edges to avoid damage to cords which may cause an electrical hazard.
- For plugs with a 3-prong, grounded type plug, do not remove the grounding pin from the plug on the power cord.
- Inspect all power cords for damage before installation, use or maintenance. Replace entire pump or transformer if damage is found.
- The included pump should only be used with portable, self-contained fountains no larger than 1.52 m / 5 ft in any direction.
- Always disconnect the pump and/or transformer from the power source before performing any maintenance on the pump, lights (if equipped), or fountain.
- Do not lift the pump and/or transformer by its power cord.
- Do not let the pump run dry. Pump must be completely submerged for proper operation and cooling.
- Do not pump heated liquids.
- The pump has been evaluated for use with water only.
- Operate fountain with fresh water only. Avoid heavily chlorinated water and water with high pH levels.
- Do not leave the fountain running unsupervised for extended periods of time.
- If equipped, please ensure all lamp holders are fitted with a bulb.
- This product is not a toy! Please keep out of reach of children and pets.

Note: Each fountain product may have minor variations in texture, finish and appearance. Some products and finishes are intentionally weathered and worn in appearance to enhance the aesthetic beauty of the finished product and make each fountain truly unique.

ASSEMBLY INSTRUCTIONS

Estimated assembly time: Approximately 15 minutes

1. Place the fountain pedestal on a flat, level surface for the assembly and location of the fountain. Attach the basin to the pedestal by aligning the locking tabs on the top of the pedestal with those on the underside of the basin. Twist clockwise to lock into place.

2. Route the pump power cord down the cord pipe through the basin and the pedestal and then out from the cord slot at the base of the pedestal.

3. Place the three submersible lights into the light sockets on the basin. Carefully wedge the light cords into the cord clips.

4. Attach the water supply tube on the underside of the fountain top to the outlet tube of the pump. Make sure the pump sits flat with the outlet facing upwards within the pump housing. If applicable, adjust the flow rate of the pump is set to the maximum (+) position. Now place the fountain top over the pump onto the basin aligning it over the ring in the basin.

5. Fill the basin with clean water. Do not fill past water line marked on the inside edge of the basin.

6. Connect the pump power cord to the transformer and then connect the transformer to a GFCI outlet. Turn your power source on and the fountain will start to flow.

7. If applicable, adjust the flow rate of the pump to the desired level. Remember to always disconnect the pump from the power source before making any adjustments to the pump or lights.

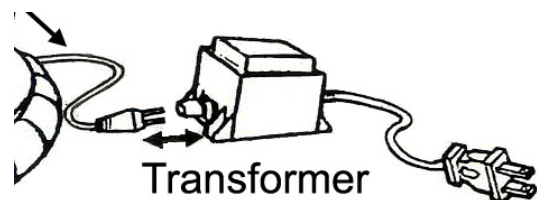
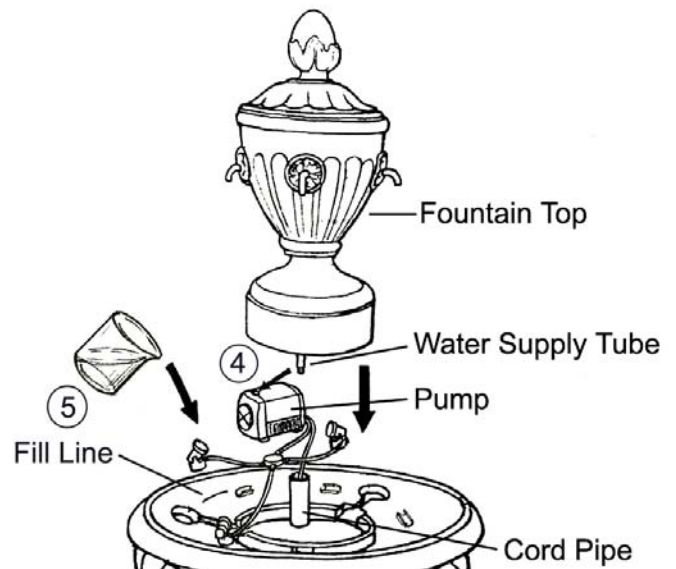
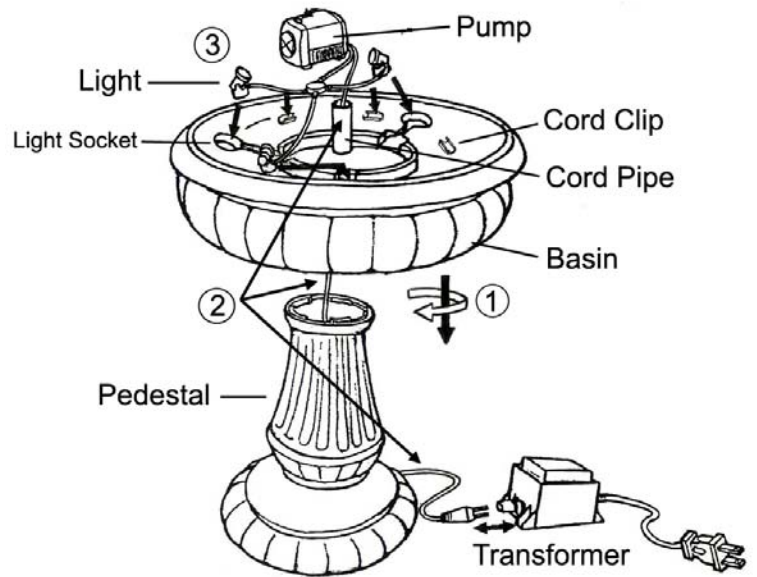

CARE AND MAINTENANCE

1. Keep the water clean and clean the fountain periodically to prevent mineral deposits and contamination which may clog the pump.
2. Use a pre-filter on your pump if available.
3. Regular cleaning of the pump will be necessary depending upon the environment in which it is operated. Clean the pump when it is visibly soiled or when a noticeable decrease in performance is detected.

Failure to clean the pump will result in overheating of the pump.

4. Before cleaning, always disconnect the pump from the power source.
5. Disassemble the pump by removing the filter and gland. Remove the impeller/rotor assembly by gently pulling on the impeller blades. Use a soft cloth or brush to clean the area inside of the pump where the impeller/rotor assembly was. Clean the filter, gland and impeller in warm soapy water. Reassemble the pump and inspect for proper operation.
6. Check the water level regularly to ensure the pump is completely submerged during operation.
7. To eliminate water damage to floors and/or surrounding fountain areas, check for leaks and excessive splashing after initial installation and on a regular basis.
8. Place the fountain in a location that will not be damaged should the area come in contact with liquids.
9. If the fountain is not in use for an extended period of time, disconnect the power and empty all the water from the fountain.
10. The fountain should not be operated in temperatures below 5° Celsius / 41° Fahrenheit to prevent frost damage. If the fountain is stored outdoors in freezing temperature, disconnect the power, empty all the water from the fountain and make sure it is completely dry.

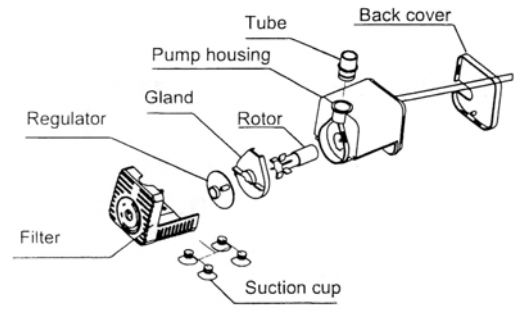

Light Bulb Replacement Instructions:

1. If an accent light bulb is burned out, unplug the transformer from the power source and allow a few minutes for the light bulb to fully cool before handling.
2. Remove the lamp's plastic cover by twisting in a counter clockwise motion and remove the transparent lens cover.
3. The bulb may now be pulled out from its socket and replaced with a new bulb (not included).

Replacement for the high intensity halogen bulb:
MR-11 type halogen bulb, 12 volts, 10 watts maximum

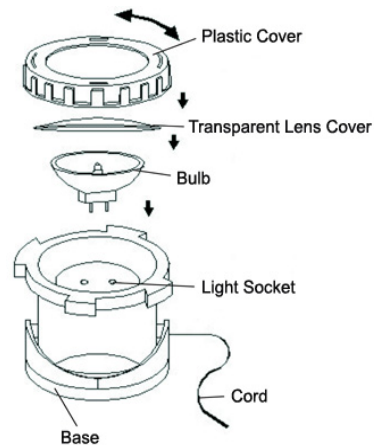

IMPORTANT SAFETY INSTRUCTIONS PERTAINING TO A RISK OF FIRE, OR INJURY TO PERSONS



WARNING - Lighted lamp gets HOT quickly. Do not touch hot lens or cover.
Unplug and allow the lamp to cool before handling the lamp.
Keep lamp away from materials that may burn.
Do not touch the bulb at any time. Use a soft cloth. Oil from skin may damage lamp.
Do not operate the lamp without bulbs or with missing or damaged lamp covers.

Troubleshooting Guide:

If the pump operates, but, there is no water flow...

1. Check to make sure the pump is fully submerged.
2. Check the supply tube for any kinks or folds and correct.

If the pump operates, but there is no water flow and the pump is fully submerged and the supply tubing has no kinks...

1. Disconnect the pump from the power source.
2. Disconnect the supply tube from the pump outlet.
3. Check for clogs or holes and clean the tubing inside and outside if necessary.
4. Check for clogs and clean the pump inlets and outlet if necessary.
5. Place the pump back into the water outlet side up and then re-connect the pump to the power source.
6. Once the water begins to flow from the pump, re-connect the supply tubing to the pump outlet.